

3DPrintMill Profile Support User Manual

3DPrintMill支架使用说明书 V1.0

1. List of profile support parts. 支架零件清单。

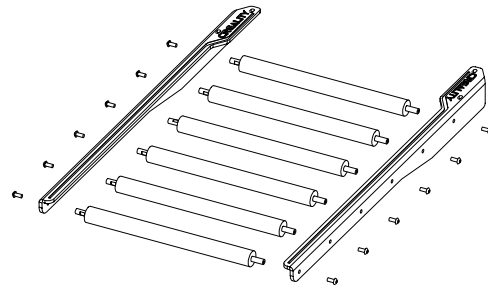

1. 辊筒左支架 X1
Left bracket of roller X 1
2. 辊筒右支架 X1
Right bracket of roller X1
3. 辊筒 X6
Rollers X 6
4. M5*12 内六角平圆头螺丝 X12
M5*12 Socket head flat round head screw X12

2. Take out the profile seal on the model and install the bracket as shown in the picture. 将机型上的型材封条取出来，按图所示将支架安装好。

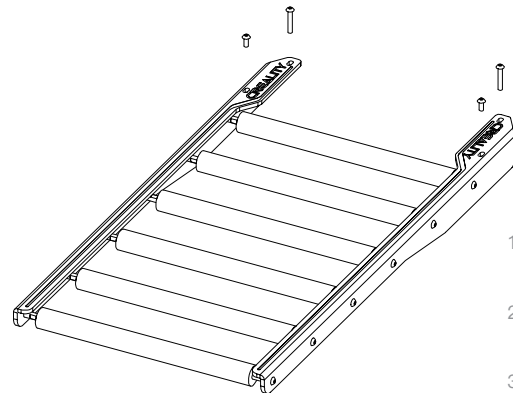

1. M5*30 Hexagon socket round screw X2
M5*30内六角平圆头螺丝 X2
2. M5*12 Hexagon socket round screw X2
M5*12 内六角平圆头螺丝 X2
3. subplate*2
垫板

3. Install the assembled bracket onto the mounting hole reserved for 3D printer. 将组装好的支架安装到3D打印机预留的安装孔上。

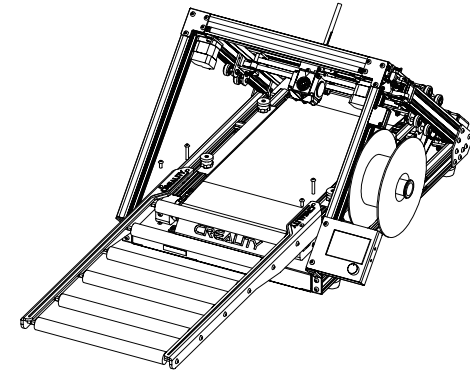

4. Renderings after installation. 安装完成后的效果图。

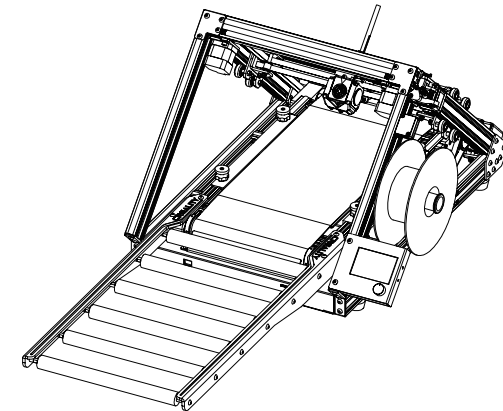

深圳市创想三维科技有限公司
SHENZHEN CREALITY 3D TECHNOLOGY CO., LTD.

Add : 18F, JinXiuHongDu Building, Meilong Blvd.,
Longhua Dist., Shenzhen, China 518131
Official Website: www.creality.com Tel: +86 755-8523 4565
E-mail: info@creality.com cs@creality.com

